

Basic contact information

Company: Zhejiang Sidite New Energy Co., Ltd

Website: www.sidite-solar.com

E-mail: info@sidite.com

Mobile Phone: 0086-18868305896

If you are interested in our products, please contact us!

Non Pressurized Flat Plate Solar Water Heater (SN-FT)

Non Pressurized Flat Plate Solar Water Heater (SN-FT), this product is mainly consist of three parts, flat plate, water tank, assistant tank. Vacuum tube solar water heater has its advantages, So does flat plate solar water heater. Such as totally copper flow channels achieve low defect rate, 2, easy maintenance, 3, long service life. And compare to SP-F, this product SN-FT is non pressurized...

Other characteristics and information, please see the details below.



Characteristic:

- 1.Elegant and smart appearance, easy installation.
- 2.Reliable electric back-up with protection against dry heating and thermal cut-out.
- 3.Easy operation and intelligent control.
- 4.Stainless steel inner tank SUS304 for good anti-corrosion.

5. With high quality flat solar collector with long service life.

6. Polyurethane insulation with good heat reservation.

7. Totally copper flow channels achieve low defect rate and easy maintenance, long service life.



Working Principle:

Under normal operating conditions the potable water within the potable storage tank is heated by the solar collectors. For example, in an close circuit system where the household hot water is in the collector circuit, cold water is pushed downwards via the long external pipe from the storage tank to the bottom of the solar collector. As the water is heated in the absorber by the sun, it rises to the top of the collector then travels through the short external pipe into the storage tank.

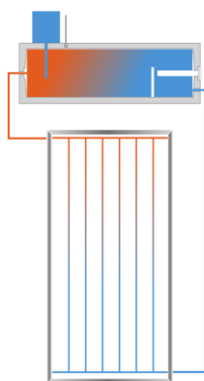

Structure Drawing :

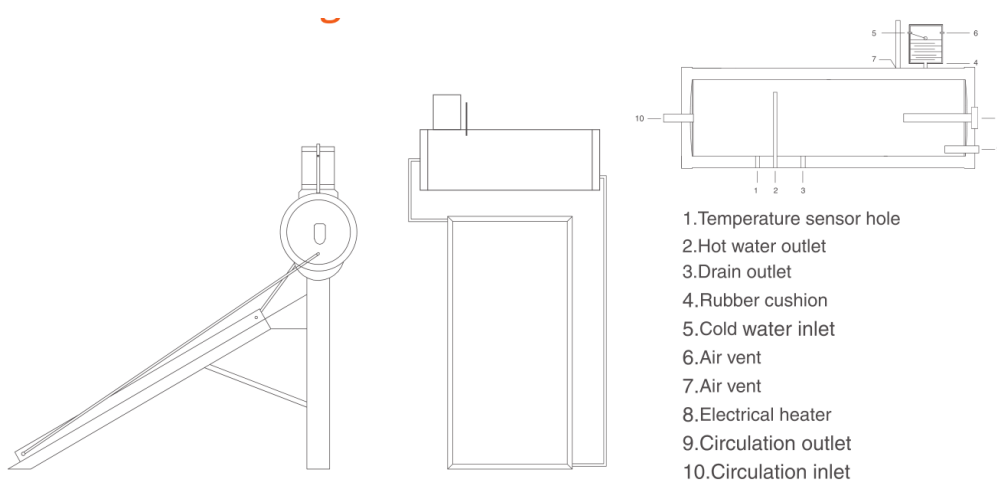

Technical Information:

Model	SN-FT-150A	SN-FT -200A	SN-FT -300A	SN-FT -150	SN-FT -200	SN-FT -300
Flat Plate Quantity(pcs)	1	1	2	1	1	2
Mounting Type	Flat Roof			Sloping Roof(15°~30°)		
Water Tank						
Net Capacity (L)	150	200	300	150	200	300
Material Of Inner Tank	SUS304					
Material Of Outer Tank	Color Steel Plate / Stainless Steel Plate					
Material Of Insulation	Polyurethane					
Flat Plate Solar Collector						
Dimension (mm)	2000 X 1000 X 80					
Coating	Black Chrome / Blue Film					
Material	Color Steel Plate T1.2 / Galvanized Steel					
Degree	0°~ 45°			0°		